

GN 417 Indexing plungers

With or without rest in retracted position, steel



- 1
- 2
- 3
- 4
- 5
- 6
- 7
- 8
- 9
- 10
- 11
- 12
- 13
- 14
- 15
- 16
- 17
- 18

BODY

Die-cast zinc alloy, epoxy resin coating, black colour, matte finish.

PLUNGER

AISI 303 stainless steel.

SPRING

AISI 301 stainless steel.

LIFTING RING

AISI 301 stainless steel.

KNOB

High-resilience polyamide based (PA) technopolymer, black colour, matte finish.

STANDARD EXECUTIONS

- GN 417-A: with lifting ring.
- GN 417-B: with lifting knob.
- GN 417-C: with lifting knob and rest position.
- GN 417-D: with eyelet reinforced ring drive.

FEATURES AND APPLICATIONS

For optimal positioning of the plunger of GN 417 indexing plungers use positioning flanges GN 417.1 (see page 799).

The GN 417-D eyelet reinforced implementation is particularly suitable for remote operation (e.g. via cable).

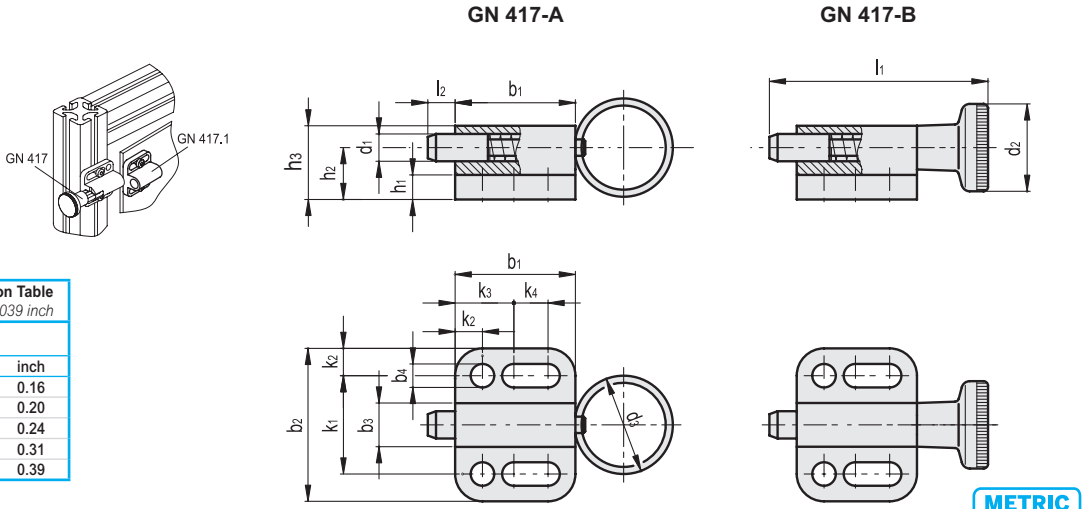

Conversion Table	
1 mm = 0.039 inch	
d1	
mm	inch
4	0.16
5	0.20
6	0.24
8	0.31
10	0.39

GN 417-A

Code	Description	d1													Spring preload [N]	Spring max load [N]	⚖️	
		Plunger h11 Hole +0.08 +0.03	d3	b1	b2	b3	b4 -0.2	h1	h2	h3	k1 ±0.05	k2	k3	k4				l2
GN.26281	GN 417-4-A	4	14	16.5	22	6	3.3	4	7	10	14	4	8	4.5	4	3	12	10
GN.26286	GN 417-5-A	5	18	22	28	8	4.3	4.5	9.5	13.5	18	5	10	7	5	5	24	19
GN.26291	GN 417-6-A	6	24	27.5	32	10	5.4	5	10.5	15.5	21	5.5	12	10	6	5	21	36
GN.26296	GN 417-8-A	8	30	33	34	12	5.4	6	12.5	18.5	23	5.5	12	15.5	8	6	22	60
GN.26285	GN 417-10-A	10	30	35	39	14.5	6.5	6	14.5	21.75	27	6	15	13.5	10	4	25	83

GN 417-B

Code	Description	d1														Spring preload [N]	Spring max load [N]	⚖️	
		Plunger h11 Hole +0.08 +0.03	d2	b1	b2	b3	b4 -0.2	h1	h2	h3	k1 ±0.05	k2	k3	k4	l1				l2
GN.26282	GN 417-4-B	4	12	16.5	22	6	3.3	4	7	10	14	4	8	4.5	30.5	4	3	12	10.5
GN.26287	GN 417-5-B	5	16	22	28	8	4.3	4.5	9.5	13.5	18	5	10	7	40	5	5	24	20
GN.26292	GN 417-6-B	6	18	27.5	32	10	5.4	5	10.5	15.5	21	5.5	12	10	49	6	5	21	37
GN.26297	GN 417-8-B	8	21	33	34	12	5.4	6	12.5	18.5	23	5.5	12	15.5	59	8	6	22	60.6
GN.26290	GN 417-10-B	10	25	35	39	14.5	6.5	6	14.5	21.75	27	6	15	13.5	67.5	10	4	25	83

Indexing and positioning elements



Conversion Table 1 mm = 0.039 inch	
d1	
mm	inch
4	0.16
5	0.20
6	0.24
8	0.31
10	0.39

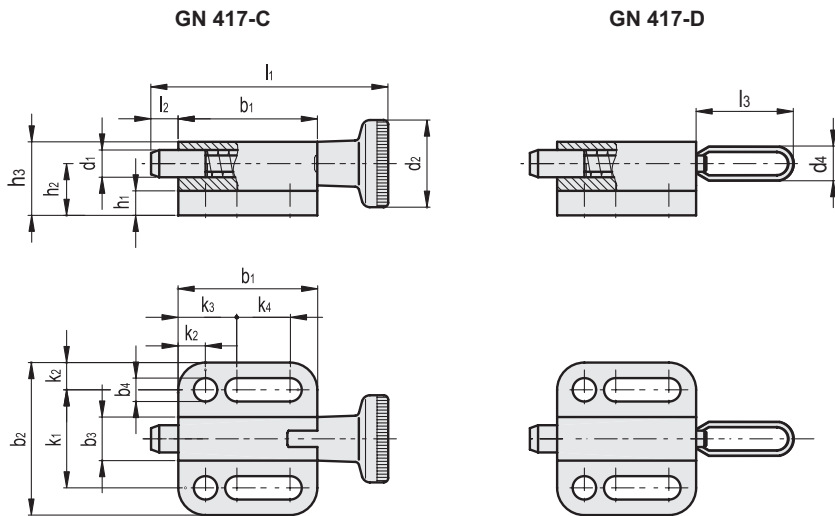

GN 417-C

METRIC

Code	Description	d1 Plunger h11 Hole +0.08 +0.03	d2	b1	b2	b3	b4 -0.2	h1	h2	h3	k1 ±0.05	k2	k3	k4	l1	l2	Spring preload [N]	Spring max load [N]	⚖
GN.26283	GN 417-4-C	4	12	19	22	6	3.3	4	7	10	14	4	8	7	33	4	3	12	10
GN.26288	GN 417-5-C	5	16	25.5	28	8	4.3	4.5	9.5	13.5	18	5	10	10.5	43.5	5	5	24	21
GN.26293	GN 417-6-C	6	18	30.5	32	10	5.4	5	10.5	15.5	21	5.5	12	13	52	6	5	21	40
GN.26298	GN 417-8-C	8	21	37.5	34	12	5.4	6	12.5	18.5	23	5.5	12	20	63.5	8	6	22	67.3
GN.26295	GN 417-10-C	10	25	40	39	14.5	6.5	6	14.5	21.75	27	6	15	13.5	72.5	10	4	25	80

GN 417-D

METRIC

Code	Description	d1 Plunger h11 Hole +0.08 +0.03	d4	b1	b2	b3	b4 -0.2	h1	h2	h3	k1 ±0.05	k2	k3	k4	l2	l3	Spring preload [N]	Spring max load [N]	⚖
GN.18653	GN 417-4-D	4	6	16.5	22	6	3.3	4	7	10	14	4	8	4.5	4	13	3	12	10
GN.18655	GN 417-5-D	5	7.2	22	28	8	4.3	4.5	9.5	13.5	18	5	10	7	5	15.5	5	24	20
GN.18657	GN 417-6-D	6	9.5	27.5	32	10	5.4	5	10.5	15.5	21	5.5	12	10	6	21	5	21	35
GN.18659	GN 417-8-D	8	11.8	33	34	12	5.4	6	12.5	18.5	23	5.5	12	15.5	8	26	6	22	56
GN.18651	GN 417-10-D	10	11.8	35	39	14.5	6.5	6	14.5	21.75	27	6	15	13.5	10	26	4	25	81